

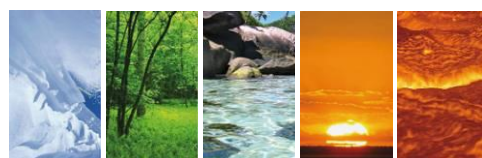

GSE



Polyvalent **geothermal** and **hydrothermal** unit:
modulating heat pump for domestic hot water and home comfort

7 to 45 kW

ENGLISH



Sommario

INTRODUCTION	4
1 DESCRIPTION OF PRODUCT	7
1.1 The GSE series	7
1.2 Operating modes	8
1.3 Components	10
2 MANAGEMENT AND CONTROL	12
2.1 HiWeb function	12
2.2 Load management function	13
2.3 Diagram of the system	15
3 INSTALLATION AND START-UP	17
3.1 Installation	17
3.2 Water connections	17
3.3 Electrical connections	19
3.4 Starting up	19
4 MAINTENANCE AND AFTER-SALES SERVICE	22
4.1 Maintenance	22
4.2 Troubleshooting	24
4.3 Safety data sheet of R410A refrigerant	26
5 TECHNICAL DATA	27
6 MECHANICAL ASSEMBLY DRAWINGS	30
7 REMARKS FOR THE USER	31

Introduction

Introduction

The ever-growing need to cool buildings during the summer and to heat them during the winter, in the last few years has brought about the diffusion of one device capable of meeting different thermal requirements: the reversible heat pump.

The principles of thermodynamics tell us that heat can be transferred spontaneously only from a warm body to a cold one. The opposite process can only be conducted with the help of external energy. The following figure represents a simply hydraulic analogy, where one can see how water flows naturally from the top tank to the one below, with the possibility of supplying mechanical energy, such as through a turbine. In a similar manner in thermodynamics, the transfer of heat from a source at a high thermal level to a lower thermal level produces mechanical energy. On the contrary, to transfer the mass of water from the downstream basin upstream, one needs a pump that uses mechanical energy. The following layout further clarifies the analogy.

Operation of a heat pump is founded on the same basis. It transfers heat from a lower temperature level to a higher one by the use of mechanics in order to obtain the desired temperature conditions (as well as humidity, if required) in the place to be air-conditioned. The unit operates a thermodynamic cycle by exploiting a heat-transfer fluid (refrigerant) which flows inside of the piping of the circuit. It consists of two heat exchangers that transfer thermal energy between the fluid and the sources, a compressor and expansion valve that

ensures a correct mass flow rate towards the evaporator under pressure-jumping conditions set by the surroundings.

Upstream basin	↔	High-T source (warm)
Downstream basin	↔	Low-T source (cold)
Upstream basin height	↔	Temperature of warm source
Downstream basin height	↔	Temperature of cold source
Natural outflow of water from upstream to downstream	↔	Spontaneous transfer of heat from the hot source to the cold source (direct cycle)
Pumping from downstream to upstream	↔	Heat pump for air conditioning (inverse cycle)

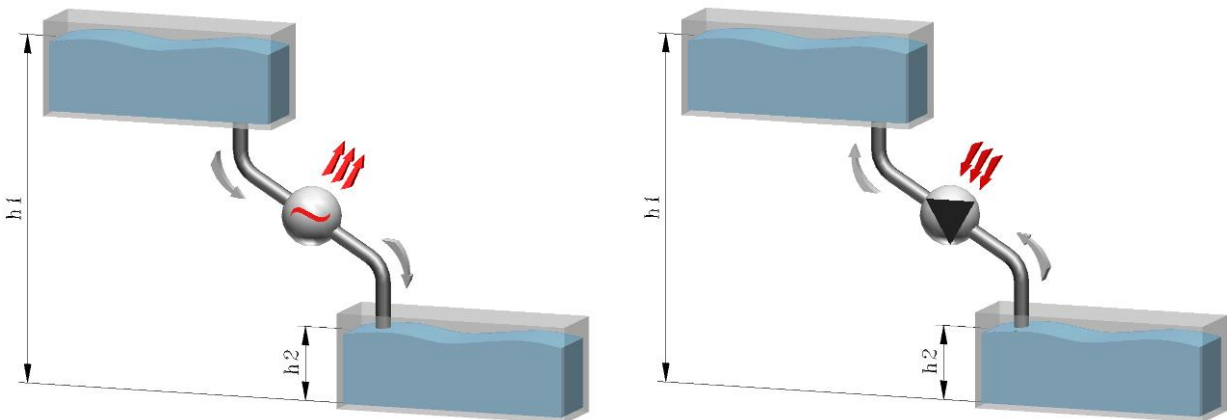

Hydraulic analogy of thermodynamic processes: natural outflow and pumping

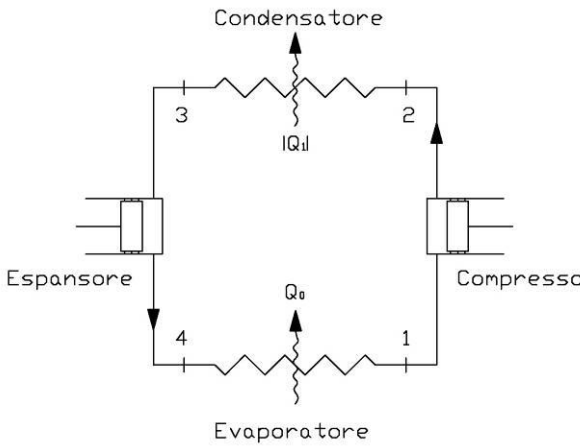

Fig. a Representative diagram of a heat pump

By administering work from the outside, the unit is therefore able to absorb the amount of heat Q_0 from a low-temperature source, thanks to the evaporation of the refrigerant, and to yield the amount Q_1 at a higher thermal level through condensation of the same refrigerant. Depending on the useful effect intended to be exploited in the atmosphere to be air-conditioned (heat absorption or release) cooling or heating is obtained respectively.

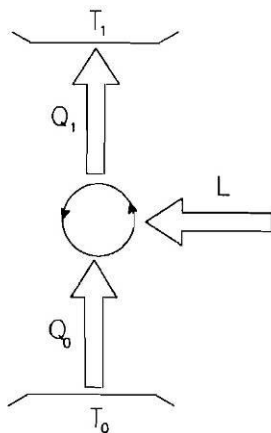

Fig. b) Thermal exchanges in an inverse cycle operated by a heat pump

Inverse Carnot cycle: (ideal)

An inverse cycle is one where the algebraic sum of heat exchanged from the operating substance between the two sources is negative and therefore the work exchanged is also negative. Let us assume T_1 and T_0 ($T_1 > T_0$) are the temperatures of the two sources, Q_1 and Q_0 the respective quantities of heat.

If the process is reversible, having always to be

$$|Q_1|/T_1 = |Q_0|/T_0$$

At the higher temperature source, the following quantity of heat is released

$$|Q_1| = |Q_0| + |L|$$

sum of heat $|Q_0|$ subtracted from the lowest temperature source and of work $|L|$ performed (fig. b).

The purpose of the cycle can be to remove heat from lower temperature bodies (chilling cycle) or to yield heat to higher temperature bodies (thermodynamic heating).

In this second situation, we commonly speak of "heat pump".

In the first case, the cycle is characterised by the ratio between the heat $|Q_0|$ subtracted from the source at temperature T_0 and the work performed:

$$\epsilon = |Q_0| / |L| = |Q_0| / (|Q_1| - |Q_0|)$$

This ratio will be called COP = "coefficient of performance" of the cycle. This does not constitute a yield and its value can be greater than the unit. Is also possible to write:

$$\epsilon = T_0 / (T_1 - T_0)$$

and this value represents the maximum COP limit of any inverse cycle (cooling) operated between the temperature T_1 and T_0 .

To remove heat from a body requires much more work the lower the temperature T_0 this body is and the cost tends towards infinity when the temperature T_0 tends to absolute zero.

If the purpose of the cycle is to yield heat to warmer bodies, the cycle is characterised by the ratio between the heat yielded at temperature T_1 and the work expended:

$$\begin{aligned} \epsilon_1 &= |Q_1| / |L| = |Q_1| / (|Q_1| - |Q_0|) \\ &= T_1 / (T_1 - T_0) \end{aligned}$$

which results in:

$$\epsilon_1 = \epsilon + 1 .$$

The coefficient of performance of a heat pump operating at the inverse Carnot cycle is always greater than the unit. This is precisely because not only is the equivalent of the work expended yielded to the higher temperature source but also the heat (free) absorbed from the lower temperature source.

Real cycle:

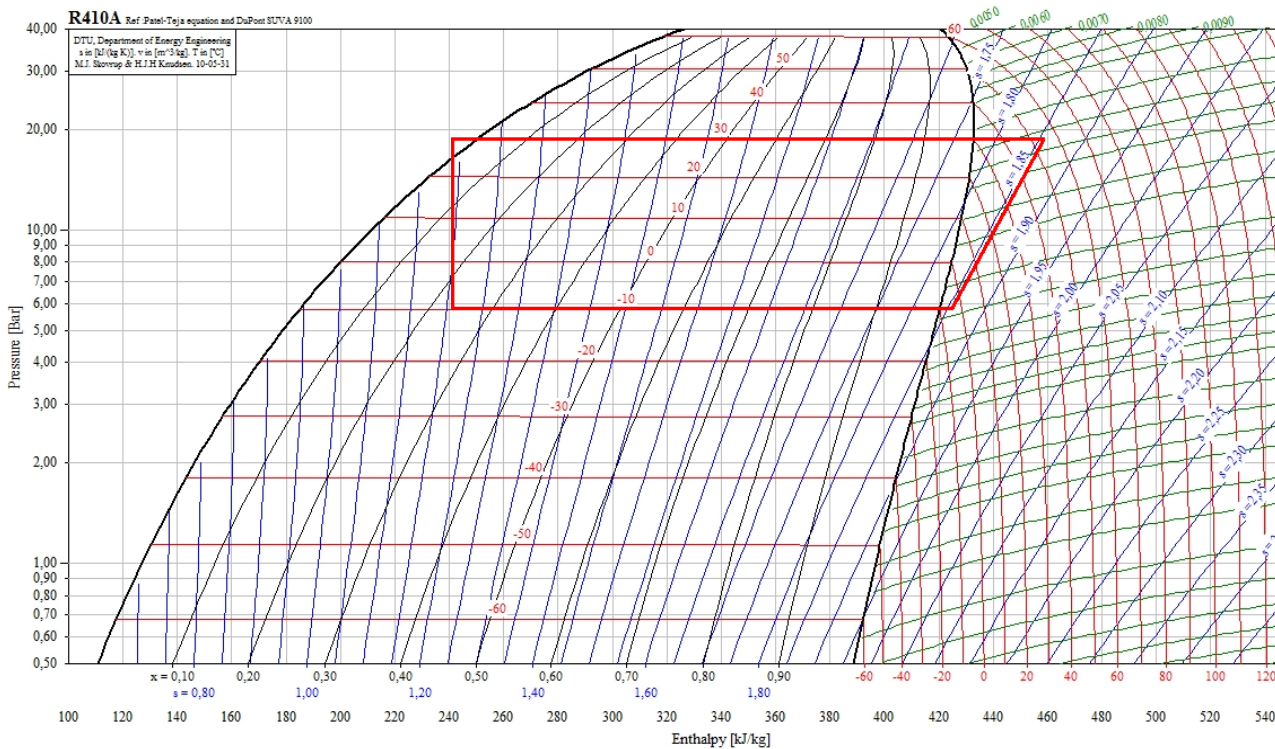

Graphical representation of inverse cycle on diagram $p-h$

A classical graphical representation of the cycle (called inverse cycle, run anticlockwise) implemented by the machine is that marked by a thermodynamic diagram $p-h$, in which the vertical axis of the ordinates shows the cooling fluid pressure and the y-axis the Enthalpy:

The four thermodynamic transformations are highlighted by the figure:

1-2: Compression of the refrigerant (to the gaseous state) from pressure level p_1 to p_2 with expended energy

2-3: Gas condensation at pressure p_2 and temperature T_2 and yield of thermal flow q_1

3-4: Isenthalpic expansion of liquid from $p_2=p_3$, $p_4=p_1$

4-1: Evaporation of mixture at pressure p_e and temperature T_e with absorption of thermal flow q_0

Two sizes must be introduced to evaluate the energy performance of the heat pump:

- the Coefficient of Useful Effect in chilling mode:

$$\varepsilon = \frac{Q_0}{|L|}$$

in which Q_0 is called Cooling Effect, namely the energy taken from the low-energy source;

- the Coefficient of Performance COP of the heat pump in heating mode:

$$COP = \frac{|Q_1|}{|L|}$$

Applying the First Principle of Thermodynamics, therefore preservation of the energy of the heat pump system, gives us $Q_0 + L = Q_1$, with the substitution obtains:

$$COP = \varepsilon + 1$$

The interest from an economical and energy point of view of obtaining the highest possible COP values is obvious. In fact, it constitutes a sort of multiplier of the precious energy supplied and makes it possible to provide more useful energy than the electricity required to run the unit.

1 Description of Product

1 Description of Product

1.1 The GSE series

GSP is a water-condensed multipurpose heat pump for residential use which absorbs/yields energy to a source, aquifer or closed-circuit geothermal plant and, without combustion, alternately heats or cools the entire home and produces domestic hot water in a fully autonomous way, in priority or total recovery in cooling mode.

The product has 4 sizes, classified according to the cooling capacity in nominal conditions, namely for water produced at 12 / 7°C with dissipation water at 30 / 35 °C:

GSE 006 – for cooling capacities of 7,0 kW
GSE 009 – for cooling capacities of 9,0 kW
GSE 012 – for cooling capacities of 12,7 kW
GSE 017 – for cooling capacities of 17,0 kW
GSE 022 – for cooling capacities of 21,0 kW
GSE 025 – for cooling capacities of 24,0 kW
GSE 030 – for cooling capacities of 28,0 kW
GSE 033 – for cooling capacities of 31,0 kW
GSE 040 – for cooling capacities of 36,0 kW



The technical features common to ENE units are:

- Expansion device: EEV (electronically-controlled expansion valve) to benefit from the possibility of

generating thermodynamic cycles under reduced pressure jumps with considerable COP advantages.

- Dissipation side, Utility side and DHW side pumps with variable speed permanent magnet motor to adapt the flow rates to actual functioning and to save significant pumping costs.
- **Dual circuit.**
 - Air conditioning circuit with cooling circuit side reversibility and set-point variable between min/max with voltage-free contact or with analogue signal 0-10V and 4-20mA, via serial communication.
 - Total heat recovery (for simultaneous cooling) or in any case prioritised DHW circuit. This circuit is separated and does not need, like similar products on the market, long heating/cooling stages of inertial storage that jeopardise energy efficiency during summer operation

The basic selection in the development of the GSP series consists in using the following:

- Scroll compressor
- AISI 316 brazed stainless steel plate heat exchangers
- Electronically controlled electric expansion valve

The structure of the **GSE** series has the following features: side panelling in galvanised sheet metal painted with polyester epoxy powders and polymerised in the oven at 180°C and a front cover that incorporates the Display, on two basic levels (LCD) and a Graphic Touch Screen. The unit is fully panelled, but can be accessed on 3 sides since the panels can easily be removed, thus simplifying maintenance and/or inspections. All routine maintenance is performed from the front of the machine

1 Description of Product

1.2 Operating modes

GSE is a multipurpose heat pump for heating, cooling, dehumidifying environments and simultaneous production of domestic hot water with priority respect to other operating modes and in total recovery in summer mode, and therefore practically free of charge.

During autumn and winter operation, GSE heats the room or produces domestic hot water. The inertia of the system, increased by the storage tank, which we recommend combining with the machine even on the heating system, also enables the priority production of domestic hot water without discomfort.

Priority production of domestic hot water, alternated with environmental heating.

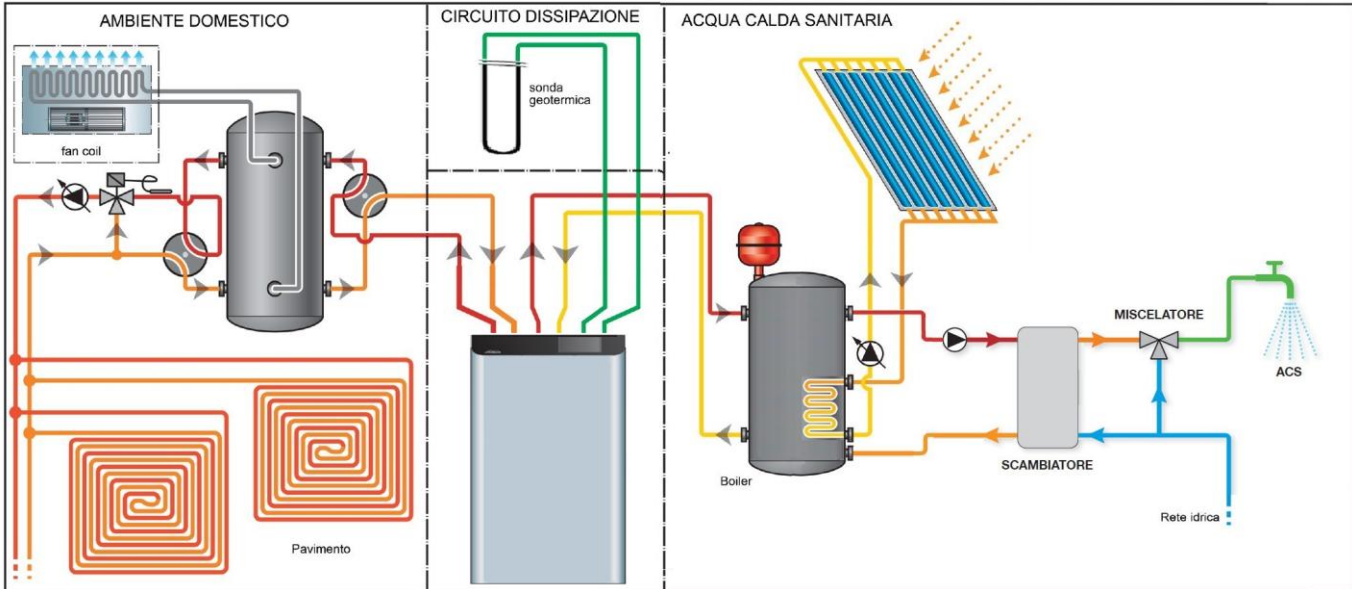

Production of domestic hot water only

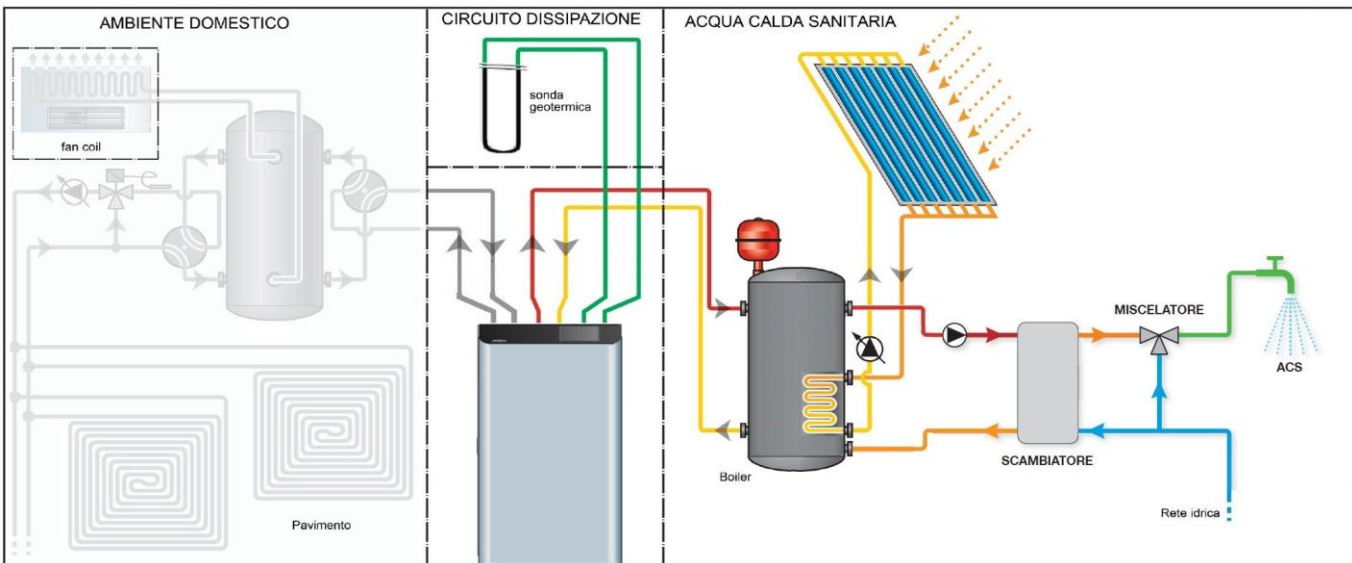

During summer operation, GSE cools and dehumidifies with humidity control and simultaneously produces domestic hot water.

1 Description of Product

practically for free. Cooling production is not interrupted during domestic hot water production (like many similar products on the market), obtaining

better comfort even with heavy enthalpic loads in the environments.

Cooling and simultaneous production of domestic hot water.

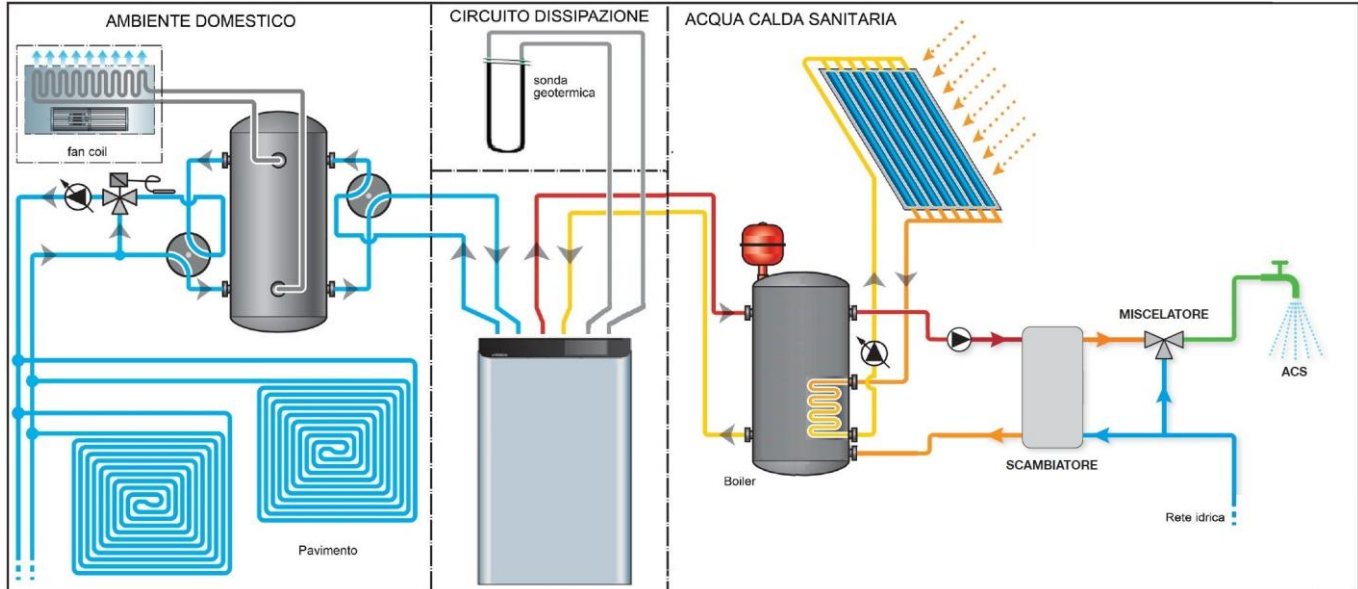

1 Description of Product

1.3 Components

- Scroll Compressor R410A

Processing optimisation together with a careful choice of the intrinsic volumetric compression ratio (ICR) allows for a significant improvement in isentropic compression performance and a consequent reduction in energy loss during the process. Low viscosity oils can be used thanks to the scroll compressor, which greatly reduce evaporator thermal resistance, compared to high viscosity oils, with an increase of over 1.5°C in the evaporation Temperature (over 5.5% in EER), with respect to alternative solutions.

Hermetic orbiting Scroll compressors supplied are complete with motor protection against overtemperature, overcurrents and excessive gas flow temperatures. Mounted on anti-vibration rubber, complete with oil charge and inserted in a soundproof compartment with sound-absorbing material. Also complete with automatic oil heater to prevent the oil from being diluted by the refrigerant when the compressor stops.



- R410A heat transfer fluid:

HFC R410A is distinguished by very favourable thermal conductivity of the liquid and negligible Glide, even if this results in a higher GWP (Global Warming Potential) than other refrigerants of the HFC family, which lead to significantly enhanced evaporation performance together with improved condenser performance. The higher operating pressures and a favourable pressure curve (temperature), allow more compact geometries of heat exchange to be used which, for the same exchange surface, feature a reduced internal volume and therefore require less refrigerant load. These factors combine in a reduction of the overall unit GWP in comparison to products with other types of environmentally friendly refrigerants of the HFC family.

Though the GWP of R410A is higher than other HFC, this is bridged by greater EER and even more so by the improved ESEER and the TEWI (total equivalent warming impact) is much less thanks to the high-induced efficiency.



The TEWI: Total Equivalent Warming Impact expresses the mass of CO₂ that produces the same overall effect as the chiller during its operational life. The main feature of this parameter consists in considering the effects of the use of refrigerant gas not only deriving from accidental emission into the atmosphere, but also the effect on global warming which the emitted carbon dioxide for energy production used to operate the chiller system under examination produces. The TEWI is expressed by a relation whose addends express the component due to indirect effect and that due to the direct effect:

$$TEWI = \alpha_{CO_2} \cdot E + GWP \cdot m_{ref}$$

- E = energy consumed by the chiller system during its operating life
- α_{CO_2} = amount of carbon dioxide emitted to produce one kWh of electrical energy, and which depends on how it is generated;
- m_{ref} = refrigerant load.

In order to assess the TEWI, it is therefore necessary to estimate the efficiency of the chiller systems from which the consumption of energy, their life, the type of energy source from which it is drawn and the mass of refrigerant contained depend.

Besides the control of emissions into the atmosphere and the choice of environment-compatible refrigerants, this type of approach also focuses on improving the overall efficiency of the chiller, which can play an important role on the actual impact that a fluid has on planet global warming, depending on the applications.

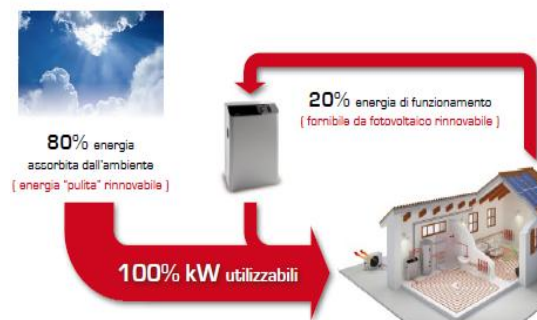

1 Description of Product

- **AISI 316 Stainless steel brazed plate heat exchangers:**

Brazed plate heat exchangers are used, made of austenitic stainless steel AISI 316 with AISI 316L connections, featured by a reduced carbon content to simplify brazing operations. The brazed plate heat exchanger represents the state-of-the-art in terms of thermal exchange efficiency and allows a strong reduction of the refrigerant load compared to standard solutions. The high degree of turbulence induced by the internal corrugation of the plates, together with their perfect smoothing features, makes it difficult for filth to deposit. In line with the powers involved, it is always recommended to choose the maximum thermal length in order to have the maximum benefits possible from the countercurrent flows.



- **Electronically-controlled electric expansion valve (EEV):**

If configured correctly and controlled properly by the software, this device helps the cooling circuit be highly efficient and this will thereby reduce the power absorbed by the system. The shutter in the central part of the valve slides vertically with an ample stroke, thereby allowing a vast variation in the opening of the fluid passage orifice.

Using this valve makes it possible to reduce energy's consumption of the compressor when the

surrounding conditions make it possible to reduce $\Delta p \Rightarrow p_{cond} - p_{ev} \lesssim 7 \text{ bar}$. Traditional expansion devices do not guarantee the same performances.



- **Circulation pumps (optional):**

Energy class A, electronically-controlled, maintenance-free, high efficiency, wet rotor circulation pumps are used with EC motors. The pump body is made of grey cast iron with a cathodolysis KTL finish, which is an excellent protection against corrosion. The thermal insulation is in polypropylene, the shaft in stainless steel, the bearings in carbon permeated with metal, and the three-dimensional scroll impeller is made of synthetic material with a hermetic insulation cladding in composite carbon fibre.



2 Management and control

2 Management and control

All the management and optimisation software of the cooling cycle, of the electronic and electromechanical components is implemented and developed in-house by a highly specialised staff.

- **Available connections for the user on GSE electric panel:**

Aside from by the display or supervisor, the unit can be piloted via external voltage-free contacts arranged

on the terminal block named X3 that has the following functions:

TERMINAL NUMBERING	FUNCTION
11-14	Remote unit On-Off
51-52	Summer/winter selection
61-62	External alarm / Second set point selection
81-82	Enable utility
91-92	Enable domestic hot water (DHW)

The unit has the following outdoor temperature probes:

TERMINAL NUMBERING	FUNCTION
63-64	Hot only utility tank probe (optional)
63-74	Outside air probe (optional)
70-73	Hot and cold utility tank probe (optional) or cold only utility tank probe (optional)
70-75	Domestic hot water (DHW) tank probe

The machine also has terminals 31-32-33 to bring a general alarm signal outside and terminals 71-72 to change the set point by means of a 0-5V or 4-20mA analogue signal.

On demand, some terminals can be added to the terminal block X3 to control external pumps:

TERMINAL NUMBERING	FUNCTION
5-6	External DHW pump power supply (optional)
7-8	External utility pump power supply (optional)
9-10	External dissipation pump power supply (optional)

These are voltage-free contacts, which can be used to give consent to external pumps.

2.1 HiWeb function

HiWeb Ethernet with HiWeb supervision software is built into the GSP unit.



The WEB board allows to connect the controller on-board the machine with the RJ45 Ethernet network at 10 Mbps. The operative system used is Linux 2.4.21 . It is installed directly on the serial port of advanced control and is used as a static or dynamic IP address with DHCP function.

2 Management and Control

HiWeb supervision software performs the following actions:

- viewing the unit status
- viewing the active alarms and alarm history
- recording data with 20 variables which can be set
- download of all the data records from the web browser or via FTP
- possibility of editing main parameters
- in case of alarm, sending e-mail to 5 different addressees

HiWeb also makes it possible to perform supervision monitoring with the following protocols:

- with SNMP v1 & v2c protocol
- with BACnet Ethernet or BACnet/IP protocol

The parameter setting relative to SNMP and BACnet protocol management is carried out by means of Administrator configuration pages, as in the figure:

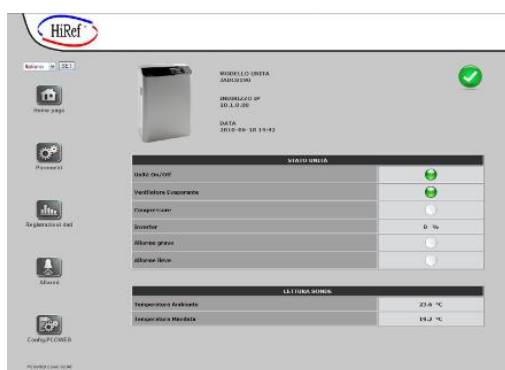

The current on board control functions are:

- control of the various operating parameters by means of a keypad set-up on the electric panel;
- compressor activation/deactivation to maintain the chiller inlet temperature set-point;
- management of various alarms such as:
 - high/low pressure
 - anti-freeze
 - flow switch
 - pump alarm
 - for the complete list see chap. 5.2
- pump management;
- displaying the operating parameters;
- heat exchanger anti-freeze protection;
- controlling the maximum number of compressor start-ups;

- controlling optional serial output with Carel or Modbus protocol (alternative to pCOWeb);
- interfacing via WEB with the Webgate option through a simple connection and any internet browser;
- summer/winter and on/off toggle from voltage-free contact or on board machine or from supervision (serial board or web interface);
- set-points set on board unit or analogue for 0-5V, or 4-20mA utility or supervision;
- **electrical load management** and automatic modulation of the unit to prevent exceeding any power limits;

2.2 Load management function

This function allows the electrical loads to be managed and priorities to be assigned to our GSP unit or other utilities, such as household appliances. This function requires a current transformer (CT) set upstream the mains meter. This CT must be of good quality (class I) and the selected ratio must guarantee a constant amperometric signal to the secondary within the 0.5 ÷ 5A range.

Its power must be equal to or greater than 5VA to guarantee regulation precision.

If it is installed away from the regulator, the dissipated power from the connection wires (approx. 0.2 VA per metre on two-wire lines with a 2.5 mm² cross-section) must be added to the normal amperometric consumption (approx. 2 VA) and that of any instruments connected in the amperometric circuit.

The following formulas can be used to calculate the real dissipated output:

$R = 2 \times r \times L/S$ (W) total RESISTANCE of the amperometric circuit

$P = (R + 0.08) \times I^2$ (VA) dissipated POWER of the amperometric circuit

r=resistivity of the conductor (0.018 for COPPER)

L= length of the connection cable of the amperometric circuit (m); S = connection cable cross-section (mm²).

I= maximum current circulating on secondary of CT
0.08= internal resistance of electronic regulator.

The wires used for the CT secondary connection must have a minimum cross-section of 2.5mm².

The CT connection must not be protected by a fuse or interrupted by an isolator switch.

The user must fit the current transformer (CT) on the line in the system to be re-phased, just upstream of both the network loads and the power supply branch point for the power factor correction panel: the CT installed must be able to measure all the currents of

2 Management and Control

the system, both inductive (motors, etc.) and capacitive (capacitors). Any capacitors for the fixed power factor correction must be installed downstream the CT, unless they are used for the power factor correction of the system power supply transformer.

Professionally qualified personnel may carry out the installation according to the instructions. The installer must connect the wires to the transformer in the correct direction for the CT to function correctly (as indicated in the structure of the CT). Otherwise, they will be connected incorrectly and result in poor performance or possibly null.

An incorrect installation can harm persons or damage objects for which the manufacturer cannot be held liable.

The CT is then connected to the GSP microprocessor, which controls the utility energy absorption, according to the power available that reaches it from the CT, with a possible derating of the GSP or turning off the other utilities, if required.

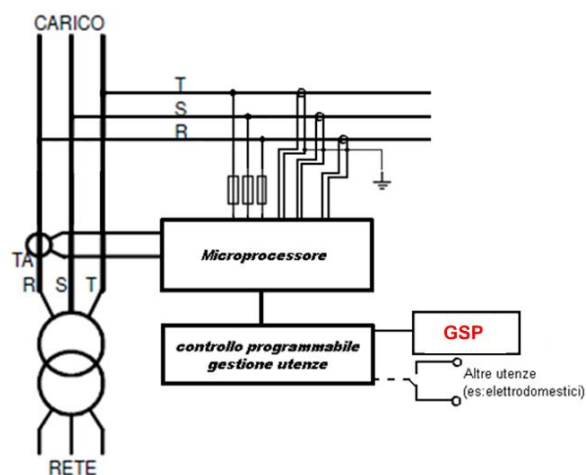

By doing so, the management and distribution of the absorbed current over time can be understood and the saved data are stored and can be downloaded via a serial port.

There is also an alternative absorbed power management function available to set the maximum output available for the unit.

This function requires selecting the available unit and meter size (sizes 3, 4.5, 6, 10, 15kW) and, depending on the condensing pressure, it will calculate the maximum speed allowed for the compressor to guarantee maximum absorption not beyond that preset.

2.3 Diagram of the system

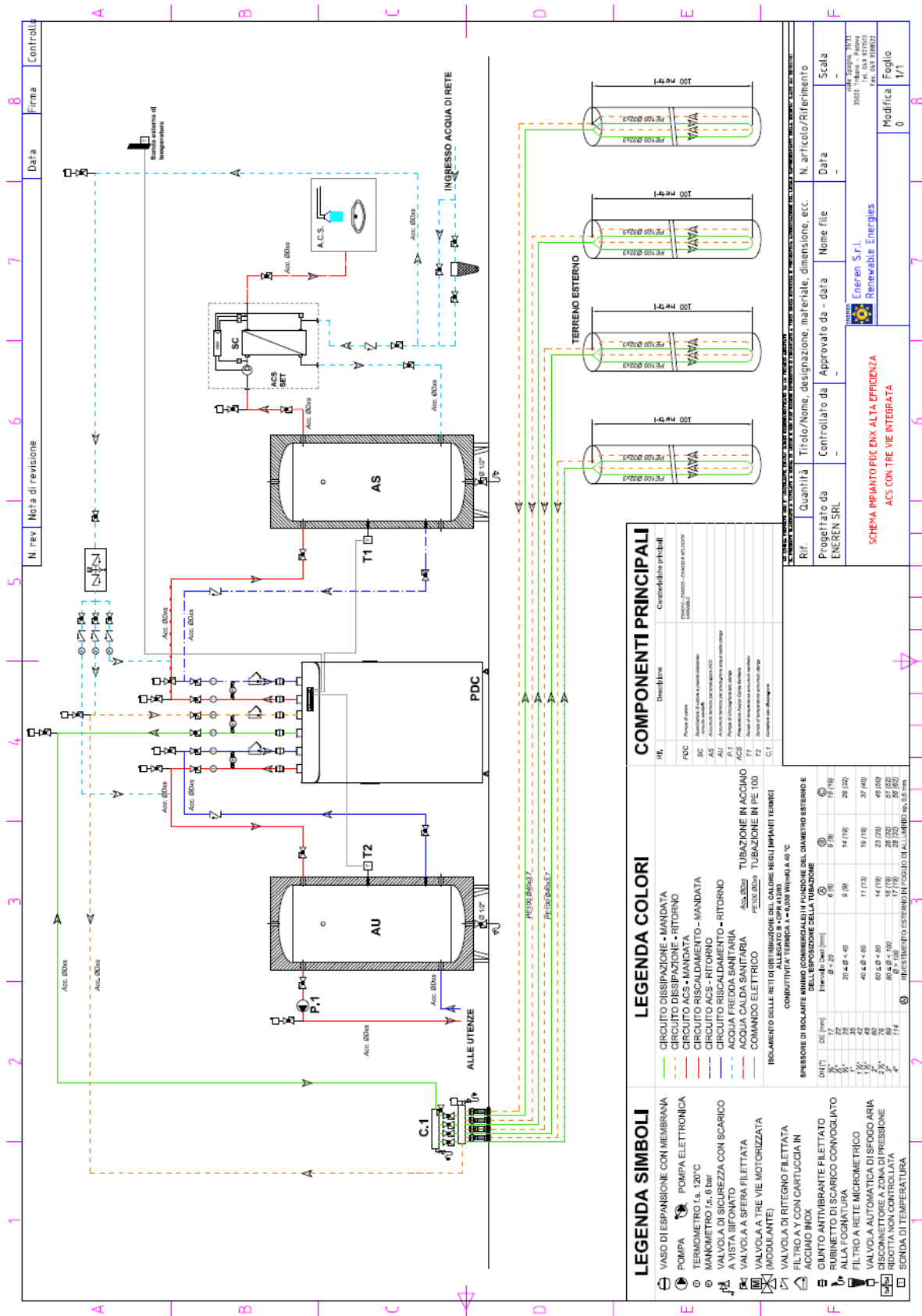

COMPONENTI PRINCIPALI

Rif.	Quantità	Titolo/Nome, designazione, materiale, dimensione, ecc.	Approvato da - data	Nome file	Data	Scala
Progettato da ENEREN SRL						
Controllato da						
Approvato da						
N. articoli/Riferimento						
Modifiche	0					1/1

LEGENDA COLORI

Dispositivo	Condizionatore principale
PDC	Pompa elettrica
SC	Scambiatore di calore a circolazione forzata
AS	Acquedotto per produzione ACS
ACS	Acquedotto per produzione ACS
T1	Termometro per produzione ACS
T2	Termometro per produzione ACS
C.1	Comando elettrico

LEGENDA SIMBOLI

	VASO DI ESPANSIONE CON MEMBRANA
	POMPA
	POMPA ELETTRONICA
	TERMOSTATO (s. 0, 120°C)
	VALVOLA A SFERA FILETTATA
	VALVOLA A TRE VIE MOTORIZZATA (MODULANTE)
	VALVOLA DI RITEGNO FILETTATA
	FILTRO A Y CON CARTUCCIA IN ACCIAIO INOX.
	GIUNTO ANTIVIBRANTE FILETTATO
	FILTRO A RETE MICROMETRICO ALLA POMPATURA
	VALVOLA AUTOMATICA DI SPOGO ARIA A PRESSIONE
	BOBBA NON CONTROLLATA
	SONDA DI TEMPERATURA

3 Installation and start-up

3 Installation and start-up

3.1 Installation

The machine left the factory in perfect conditions, however when receiving the unit verify its integrity. Immediately report any damage to the carrier and write it down on the Delivery Note before signing it. ENEREN S.r.l. or its Agent must be promptly notified concerning the extent and type of damage.



Warning: During all lifting operations make sure the unit is firmly anchored, to prevent it from tilting or falling.

Carefully remove any packaging to avoid damaging the machine. Different packaging materials are used: wood, cardboard, nylon etc. Keep them separated and dispose of them at appropriate waste disposal or recycling facilities in order to minimise their environmental impact.

Once the machine is positioned, take off the bolts to remove the pallet. Then push the unit from below and slide it to its proper position.

Bear in mind the following when choosing the best site for installing the unit and the connections:

- size and origin of water pipes;



Should refrigerant leak in the vicinity of open flames or in a room without sufficient air exchange, it could catch fire and the combustion products could harm people.

The hydraulic connections are all foreseen on the right side of the unit, when looking at the front panel. This way the back of the unit can be against the wall. It is essential to ensure the following service spaces:

- rear side: min. 0 m
- front side: min. 1.0 m to guarantee accessibility to components for maintenance
- right and left side: min. 0.5 m
- top side: min. 0.5 m



When installing the unit, for safety purposes, make sure that the room temperature does not exceed 50°C (with unit on or off).

3.2 Water connections

When setting up the water circuit for the evaporator follow the instructions below and comply with national or local standards (use the diagrams attached to this document as reference). **Fit the piping to the cooler with flexible joints to dampen vibrations and to compensate thermal expansion.** Refer to the technical data table for the type and dimensions of the hydraulic connections.

It is recommended to install the following components on the piping:

- temperature and pressure indicators for routine maintenance and inspections of the unit. Pressure control on the water side allows expansion vessel operation to be checked and any water leaks in the system to be detected in advance.
- sumps on inlet and outlet piping for measuring temperatures, and for directly viewing the operating temperatures. They can also be viewed on the display on board the unit (if pCO).
- shut-off valves (gate valves) to isolate the unit from the water circuit for maintenance.
- **metal mesh filter (incoming pipes), with a mesh not to exceed 1 mm, to protect the**

3 Installation and start-up

exchanger from scales or impurities present in the pipes. This is especially important during commissioning.

- air vent valves, placed on the higher parts of the water circuit, that bleed the air. The internal pipes of the machine are fitted with manual air vent valves to bleed the unit: **this operation can only**

be carried out when the unit is disconnected from the power supply

- discharge cock and, if necessary, drain tank to empty the system for maintenance or seasonal stops
- For process applications, it is recommended to install a decoupling heat exchanger, which avoids the fouling of the heat exchangers



It is extremely important that the water inlet is connected at the height of the "Water Inlet" sign.

If not, the evaporator would be exposed to the risk of freezing, since the anti-freeze thermostat would not be able to perform its function. Furthermore, in the cooling mode, countercurrent circulation would not be

activated. Additionally, this position does not enable consent of the water flow control device.

The dimensions and position of the water connections are provided in the dimensional tables and overall drawings.



The water circuit must guarantee a constant nominal flow rate of water (+/- 15%) to the evaporator in all operating conditions.



Warning: Never perform hydraulic connection operations with open flames near or inside the unit.



The tank is not designed to withstand vacuum pressures greater than -0.15 Bar. For this reason, make sure that the pressure on the pump intake side, where the expansion vessel is positioned, is always above 0.5 Bar with pump running. This helps reduce the risk of cavitation.

It is extremely important that the installer follows and verifies this procedure step-by-step to prevent the risk of tank implosion or pump cavitation:

- Drain the expansion vessel in the system until the pressure reaches 0.5 bar
- Fill the system and pressurise it to approximately + 1 bar in pump suction (pump stopped)
- Bleed the system
- Check the pump suction pressure (approximately 1 bar) and start up the system
- Stop the pump after 15-30 minutes. Repeat the procedure from step 3 until no more air system noise can be heard.

3 Installation and start-up

3.3 Electrical connections



Before carrying out any operation on electrical parts, make sure that the power supply is disconnected.

Check that the mains electricity supply is compatible with the specifications (voltage, number of phases, frequency) shown on the unit rating plate.

In ENE 017-022-025-030-033-040, the power connection is made by means of a three-core cable plus "N" neutral point cable to power single-phase

loads (power supply without neutral optional); the power supply is single-phase in ENE 006-009-012.

The supply voltage must not fluctuate more than $\pm 5\%$ and the imbalance between phases must always be below 2%.



The size of the cable and line protections must conform to the specifications provided in the wiring diagram.



The machine must operate within the above values, or the warranty will be invalidated.

Carry out the electrical connections following the wiring diagram provided with the unit, as well as current regulations.

An earth connection is **mandatory**. The installer must connect the earthing wire with the earthing terminal on the electric panel (yellow and green wire).

The power supply to the control circuit is shunted from the power line through a electric panel transformer.

The control circuit is protected by fuses or automatic switches, depending on the size of the unit.

3.4 Starting up

- Check that the electrical connections have been made properly and that all the terminals **are securely tightened**. This check should also be included in a periodic six-month inspection.

- Verify that voltage on the terminals is that intended on the plate $\pm 5\%$.

- Make sure there are no refrigerant leaks that may have been caused by accidental impacts during transport and/or installation. Check the power supply of the crankcase heating elements, where present. To verify whether the heating elements are working properly, check the bottom of the compressors: it should be warm or in any case 10 - 15°C higher than the ambient temperature.

The diagram illustrates the characteristic [Charles' law] of gas to dissolve in a liquid in proportion to the pressure and the simultaneous contrasting action of the temperature: with constant pressure in the sump, an increase of the oil temperature decreases the quantity of refrigerant dissolved significantly, thus ensuring the maintenance of the desired lubrication characteristics.

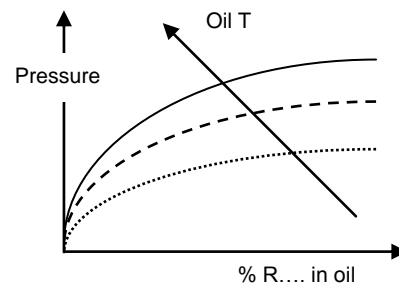

- Check that the water connections have been properly made according to the indications given on the plates located on the unit itself (proper inlet and outlet connections).

- Make sure that the water circuit is duly bled to completely eliminate the presence of air: fill the circuit gradually and open the air vent valves on the top part, which the installer should have set in place.

3 Installation and start-up

- **Instructions**

Water Connections:

- Attention: the machine is loaded with HFC R410A refrigerant – Group II EN 378 (non-hazardous substances) and in compliance with that prescribed by the EEC regulation 2037/00.
- Water connections must be carried out respecting the inlets and outlets as marked on the connections. In particular, pay the utmost attention not to swap the condenser and evaporator circuits.
- Provide cut-off valves on the water side to be able to intercept the unit respect to the system and insert a net filter (which can be inspected) both on the evaporator side and on the condenser side.
- Load the hydraulic circuit making sure to bleed all the air inside of it.

Electrical connections:

- Select the suitable cable and protection based on the indicated previously.
- Check that the mains voltage is compatible with that of the unit and that it remains within the required range.
- Check that the available power output is compatible with the maximum output absorbed by the machine.
- Disconnect the upstream protection and the circuit breaker Q1 of the unit.
- Connect the earth cable in the specific yellow/green terminal.
- Connect the phases and the neutral wire on the circuit breaker Q1. The correct phase sequence does not need to be respected as the inverter piloting the compressor generates the correct sequence regardless of the power supply.
- Rearm the upstream protection.



You should not disconnect the unit from the power supply during periods when it is idle but only when it is to be taken out of service for a prolonged period (e.g. at the end of the season).

- **Checks during operation**

- Check that the temperature of the water entering the evaporator is close to the service thermostat set value.
- After a few hours of operation, check that the liquid indicator light has a green ring: yellow indicates the presence of humidity in the circuit. In such a case the circuit must be dehumidified by qualified personnel.
- Large quantities of bubbles should not appear through the liquid level indicator. A constant passage of numerous bubbles may indicate that the refrigerant level is low and needs to be topped up.

- Rearm the circuit breaker Q1.
- Check that the controller is powered.
- Close the panel.

Start-up:

- Check that all external valves of the water circuit are open and water flows properly (the flow alarm should not be triggered).
- Put the main switch at the ON position.
- Start the unit by acting on the specific display.
- The unit will set up to meet the external requirements.
- At the end of the set-up, the pumps will start
- After the pumps starting time, the compressor will start
- Check the water temperature differential (12-7°C to be detected by means of a thermometer on the inlet and outlet water pipes of the unit).
- Check that there are no leaks on the refrigerant side and water side.
- Using all the screws supplied, close the unit.

Use:

- consult the manual supplied with the unit for all maintenance and/or advanced set-up operations.

Before starting the unit, turn the main switch off, select the operating mode desired from the control panel and press the "ON" button on the control panel. The unit will start up if enabled:

- by the safety devices of the water circulation pump/s
- by the flow switch (or differential pressure switch)
- by the T sensor measuring the temperature of the water returning from the system [chiller inlet]
- and no alarms have been triggered.

If the unit fails to start up, check whether the service thermostat has been set at the rated calibration values.

- Also check that the end-of-evaporation temperature shown on the pressure gauge (refer to the pressure gauge scale for the refrigerant R410A) is no more than about 4 °C above the temperature of the water leaving the evaporator.
- Make sure the overheating of the refrigerant fluid is limited to between 5 and 8°C. To do this, you should:
 - read the temperature indicated by a contact thermometer placed on the compressor intake pipe;
 - read the temperature indicated on the scale of a pressure gauge likewise connected to the intake side; refer to the pressure gauge scale for the refrigerant R410A.

3 Installation and start-up

The degree of superheating is given by the difference between the temperatures thus determined.

- Make sure that subcooling of the refrigerant fluid is limited to between 3 and 5°C. To do this:
 - read the temperature indicated by a contact thermometer placed on the condenser outlet pipe;

- read the temperature indicated on the scale of a pressure gauge connected to the liquid inlet at the condenser outlet; refer to the pressure gauge scale for the refrigerant R410A.

The degree of subcooling is given by the difference between the temperatures thus determined.



Warning: The refrigerant R410A requires polyolester oil "POE" of the recommended type and viscosity. Contact our head office to buy this lubricant. Do not buy from the open market due to the specific additives not present in commercial products.
For no reason should a different type of oil be introduced into the oil circuit.



To stop the unit do not disconnect it using the main switch: this device must only be used to disconnect the unit from the power supply without current flow, i.e. when the unit is switched OFF. Moreover, if you completely disconnect the unit from the electricity supply, the crankcase heating elements, if included, will receive no power, thereby jeopardising the integrity of the compressor the next time the unit is started.

4 Maintenance and after-sales service

4 Maintenance and After-Sales Service

4.1 Maintenance

Operating these units reduces itself to turning them on and off and to seasonal changeover between cooling and heating. All other operations are part of maintenance and must be carried out by qualified

personnel capable of working in compliance with laws and standards in force.

To make sure performance remains constant in time, it is recommended to respect the following maintenance and control schedule:

Activity	Frequency
Check the efficiency of all the control and safety devices.	Yearly
Check the terminals on the electric control board and compressor terminal boards to ensure that they are securely tightened. The movable and fixed contacts of the contactors must be periodically cleaned and replaced whenever they show signs of deterioration.	Yearly
Check the refrigerant level by means of the liquid level indicator.	Every 6 months
Check the oil levels through the indicators provided on the compressor crankcases.	Every 6 months
Check the water circuit for leaks.	Every 6 months
If the unit is to remain inactive for a long period of time, discharge the water from the piping and from the heat exchanger. This operation is of the utmost importance especially when there are periods while the unit is idle in which the temperature drops below the freezing point of the fluids used.	Every 6 months
Check that the water circuit is full.	Every 6 months
Check the efficiency of the flow switch or differential pressure switch.	Every 6 months
Clean the metal mesh filters mounted externally on the water pipes.	Commissioning
Check the humidity indicator on the liquid level indicator (green=dry, yellow=humid); if the indicator is not green as shown on the indicator sticker, replace the filter.	Every 6 months

• Repairing the cooling circuit



Attention: while performing repairs on the cooling circuit or maintenance work on the compressors, make sure the circuit is left open for as little time as possible. Even if briefly exposed to air, ester oils tend to absorb large amounts of humidity, which results in the formation of weak acids.

If the cooling circuit has undergone any repairs, the following operations must be carried out:

- tightness test;
- emptying and drying of the cooling circuit;
- charging with refrigerant.



If the system has to be drained, always recover the refrigerant present in the circuit using suitable equipment; the refrigerant should be handled exclusively in the liquid phase.

• Tightness test

Fill the circuit with anhydrous nitrogen supplied from a tank with a pressure-reducing valve until the pressure rises to a max of 28 bar. The presence of

any leaks must be determined using special leak detectors. Should any leaks be detected during the

4 Maintenance and after-sales service

test, empty out the circuit before repairing the leaks with suitable alloys.



During the pressurisation phase, do not exceed the pressure of 28 bar-r on the low pressure side.



Do not use oxygen in the place of nitrogen, since this could cause a risk of explosion.

• **Emptying and drying of the cooling circuit**

To achieve a hard vacuum in the cooling circuit it is necessary to use a pump capable of generating a high degree of vacuum, i.e. 150 Pa of absolute pressure with a flow rate of about 10 m³/h. If you have this pump, one vacuum operation should be sufficient to reach the absolute pressure of 150 Pa. If such a vacuum pump is not available, or whenever the circuit has remained open for long periods of time, you are strongly recommended to adopt the triple evacuation method. This method is also recommended when there is a presence of humidity within the circuit. The vacuum pump should be

connected to the inlets. The procedure to be carried out is as follows:

- Evacuate the circuit until you reach an absolute pressure of at least 350 Pa. At this point inject nitrogen into the circuit until you reach a relative pressure of about 1 bar.
- Repeat the operation described above.
- Carry out the step described above for the third time, but in this case attempting to reach the hardest vacuum possible.

Using this procedure you can remove up to 99% of pollutants.

• **Restoring R410A refrigerant load**

- Connect the tank of refrigerant gas to the male 1/4 SAE inlet situated on the liquid line after discharging a little gas to eliminate air in the connection pipe.
- Carry out the charging operation with the refrigerant in liquid form until you reach 75% of the total charge.
- Then connect to the inlet on the piping between the thermostatic valve and the evaporator and complete the charging process with the refrigerant in liquid form until no more bubbles can be seen on the liquid level indicator and the operating parameters indicated in this document have been reached.



Charge by means of the liquid line load inlet.



A unit that was originally charged with R410A in the factory cannot be charged with R22 or other refrigerants without written consent by HiRef.

• **Environmental protection**

The law [reg. EEC 2037/06] that regulates the use of stratospheric ozone depleting substances and greenhouse gases bans disposal of refrigerant gases in the environment and requires whoever is in their possession to collect them and, at the end of their

useful life, return them to the dealer or take them to a suitable waste collection facility.

The HFC R410A refrigerant is not harmful to the ozone layer but is included among the substances responsible for the greenhouse effect and thus falls within the scope of the aforesaid regulations.



Therefore, special care should be taken when carrying out maintenance work to minimise refrigerant leaks.

• **4.1.6 Warnings**

4 Maintenance and after-sales service



All the operations described in this chapter **MUST ALWAYS BE PERFORMED BY QUALIFIED PERSONNEL.**



Before carrying out any work on the unit or accessing internal parts, make sure you have disconnected it from the mains electricity supply.



The top part and the supply piping of the compressor are at high temperatures. Be especially careful when working close by with open panelling.



Be especially careful when working in proximity of finned coils since the 0.11 mm-thick aluminium fins can cause superficial injuries due to cuts.



After completing maintenance jobs, always replace the panels enclosing the units and secure them with the fastening screws provided.



When installing the unit, for safety purposes, make sure that the room temperature does not exceed 50°C (with unit on or off).

4.2 Troubleshooting

On the next pages you will find a list of the most common causes that may cause the chilling unit to fail or malfunction. They are listed according to the easily identifiable symptoms.

Use extreme caution in executing the suggested operations for the solution of various issues:

excessive confidence may cause even serious injury, to inexperienced people. It is therefore recommended to contact the manufacturer or a qualified technician after having identified the cause.

FAULT	Analysis of possible causes	Corrective actions
The unit does not start-up	No electrical power supply.	Check its presence both on the primary and auxiliary circuit.
	The circuit board is not powered.	Check the fuses.
	There are alarms present.	Check the microprocessor panel for the presence of alarms, eliminate their cause and restart the unit.
	There is no demand	Check the consents from the digital inputs and/or from supervision. Check the on-off status of the unit Check the setpoints Check the correct positioning of the probes generating the call
Faulty high pressure	Insufficient water flow rate to condenser.	Check that the circulation pumps work properly.
		Check the condenser water inlet temperature.
		Make sure that the system is pressurised properly.
	Air in the circuit, detected by air	Drain and pressurise the circuit

4 Maintenance and after-sales service

	bubbles on the flow indicator and sub-cooling values reaching over 5°C.	and then verify whether there are any leaks. Drain the circuit slowly [more than 3 hours] up to 15 Pa and then recharge in the liquid phase.
	Unit too loaded detectable by sub-cooling greater than 8 °C.	Discharge circuit.
	Clogged thermostatic valve and /or filter. Such faults may occur in the presence of low pressure.	Check the temperature upstream and downstream the valve and filter and have them replaced if needed.
	Insufficient water flow rate if heat pump is operating.	Check the pressure drops of the water circuit and/or the correct operation of the pump [rotation direction]. Check the outlet water T and make sure it is 45 °C or less.
Low condensation pressure	Faulty transducers.	Check the transducers and the correct operating of the depressor on the Schrader valves to which they are connected.
	Dissipation side temperature too low	Mount the condensation controller.
	Low water temperature if heat pump is operating.	Make sure the thermal load is adequate to the power of the unit.
Low evaporation pressure	Low water flow rate.	Check the correct rotation of the pumps. Check for pressure drops on the hydraulic circuit. Check the tightness of the one-way valve of the pump unit (optional).
	Malfunctioning of thermostat valve.	Check its opening, and adjust if necessary, by heating the bulb by hand. If there is no response, replace it.
	Clogged filter.	Load loss through the filter must not exceed 2°C (saturation temperature). Should it happen, replace the filters.
	Low condensation temperature.	Make sure the condensation control works properly [if present].
	Low refrigerant load.	Check the charge by measuring the sub-cooling; if it is below 2°C, charge with refrigerant
	Evaporator frosted if heat pump is operating.	Check the correct efficiency of the anti-freeze mixture, if foreseen.
The compressor does not start.	Internal thermal protector tripped.	Check the status of the thermal contact in models equipped with protection modules. Identify the causes after restarting.
	Tripping of circuit breakers or fuses in line after short circuit.	Check the cause by measuring the resistance of the individual coils and the isolation towards the chassis before re-connecting the power.
	Intervention of HP or LP switches.	Check the microprocessor, eliminate the causes.

4 Maintenance and after-sales service

4.3 Safety data sheet of R410A refrigerant

- IDENTIFICATION OF RISKS

PHYSICAL AND CHEMICAL RISKS: Thermal decomposition in toxic and corrosive products
SPECIFIC / EC RISKS: Preparation is not classified as dangerous

- FIRST AID

INHALATION: Move the person in question to fresh air
If necessary, provide oxygen or artificial respiration
CONTACT WITH SKIN: Rinse with plenty of water. Frostbite must be treated as thermal burns
CONTACT WITH THE EYES: Rinse immediately, with plenty of water and for a long time. If the irritation persists, consult an ophthalmologist
INGESTION: Hospitalization
PROTECTION OF RESCUERS: Wear suitable respiratory equipment when intervening in a saturated atmosphere
INSTRUCTIONS FOR THE DOCTOR: Do not administer catecholamines (due to the cardiac sensitization caused by the product)

- FIRE PREVENTION MEASURES

SPECIFIC HAZARDS: Thermal decomposition in toxic and corrosive products

- Hydrofluoric acid
- Carbon oxides
- One of the ingredients of this preparation forms explosive mixtures with air. (FORANE 32)

SPECIFIC METHODS OF INTERVENTION: Cool the containers / tanks with jets of water. Prohibit all sources of sparks and ignition - Do not smoke
SPECIAL PROTECTION SYSTEMS FOR FIRST AID SQUADS:
Wear breathing apparatus and protective clothing

- MEASURES IN CASE OF ACCIDENTAL DISPERSION

PERSONAL PRECAUTIONS: Avoid contact with your skin, eyes and inhalation of vapours.
Use personal protective equipment

In an enclosed area: ventilate or use breathing apparatus (risk of anoxia)
No smoking
ENVIRONMENTAL PROTECTION PRECAUTIONS:
Minimise waste in the environment

- HANDLING AND STORAGE

Applicable product storage and handling provisions :
PRESSURISED LIQUEFIED GAS
Provide ventilation and an appropriate exhaust system in line with the equipment
Recommendations for use: Prohibit sources of ignition and contact with hot surfaces. DO NOT SMOKE
Technical measures/Storage methods: Store in the original container at room temperature
Keep away from open flames, hot surfaces and sources of ignition
Store in a cool and well ventilated area
Protect the full containers from sources of heat in order to prevent overpressure
Recommendations: Ordinary steel
To be avoided: Alloy containing more than 2% magnesium. Plastic materials

- PERSONAL EXPOSURE PROTECTION/CONTROL

PRECAUTIONS TO BE TAKEN: Make sure there is enough air recirculation and/or intake in the workplace
CONTROL PARAMETERS: -
Exposure limit values:

FORANE 32 :
USA-AIHA 2001 : WEEL (8 h) = 1000 ppm (4910 mg/m³)
Recommended limit value: VME = 1000 ppm (2130 mg/m³)

FORANE 125 :
Recommended limit value: VLE = 1000 ppm (4900 mg/m³)
PERSONAL PROTECTIVE EQUIPMENT:

Respiratory protection: Wear suitable respiratory equipment in case of insufficient ventilation
Hand protection: Gloves
Eye protection: Safety goggles

5 Technical data

5 Technical data

		GSE006	GSE009	GSE012	GSE017	GSE022	GSE025	GSE030	GSE033	GSE040
Chilling										
@ 12/7°C utility										
30/35°C source 20% glycol										
Cooling Capacity	[kW]	7.02	8.82	12.6	17.0	20.8	23.9	28.0	31.7	35.7
Cooling Capacity UNI EN 14511	[kW]	7.07	8.87	12.7	17.0	20.9	24.0	28.1	31.8	35.8
Compressor Absorbed Power	[kW]	1.63	2.05	2.92	4.11	4.99	5.60	6.55	7.35	8.49
Absorbed Power UNI EN 14511 with pumps on board	[kW]	1.51	1.93	2.80	3.98	4.87	5.46	6.40	7.18	8.42
Compressor Absorbed Current	[A]	7.86	9.90	14.12	6.59	8.01	8.99	10.51	11.78	13.61
EER	[-]	4.32	4.31	4.31	4.13	4.17	4.27	4.27	4.31	4.21
EER UNI EN 14511	[-]	4.67	4.59	4.52	4.28	4.29	4.40	4.38	4.42	4.25
UTILITY Water Flow Rate	[kg/h]	1205	1515	2165	2915	3578	4106	4807	5442	6135
UTILITY Water Pressure Drops	[kPa]	10	14	13	14	20	15	20	17	21
UTILITY Water effective head	[kPa]	58	51	61	58	75	70	94	93	85
SOURCE Water Flow Rate	[kg/h]	1567	1971	2816	3821	4681	5350	6261	7076	8014
SOURCE Water Pressure Drops	[kPa]	8	12	14	24	23	22	27	27	33
SOURCE Water effective head	[kPa]	58	50	59	70	60	49	79	72	95
Chilling										
@ 23/18°C utility										
30/35°C source 20% glycol										
Cooling Capacity	[kW]	9.92	12.3	17.5	23.4	28.8	32.8	38.5	43.8	49.2
Cooling Capacity UNI EN 14511	[kW]	9.97	12.4	17.5	23.4	28.8	32.9	38.5	43.8	49.2
Compressor Absorbed Power	[kW]	1.61	2.08	2.91	4.30	5.12	5.89	6.77	7.59	8.95
Absorbed Power UNI EN 14511 with pumps on board	[kW]	1.50	2.01	2.86	4.26	5.13	5.91	6.79	7.66	9.08
Compressor Absorbed Current	[A]	7.77	10.05	14.06	6.90	8.21	9.44	10.87	12.17	14.35
EER	[-]	6.17	5.94	6.00	5.43	5.62	5.58	5.68	5.77	5.50
EER UNI EN 14511	[-]	6.65	6.15	6.23	5.50	5.62	5.55	5.68	5.72	5.42
UTILITY Water Flow Rate	[kg/h]	1709	2129	3013	4029	4967	5662	6642	7552	8487
UTILITY Water Pressure Drops	[kPa]	18	27	24	25	36	27	36	31	38
UTILITY Water effective head	[kPa]	45	33	46	40	43	38	66	61	46
SOURCE Water Flow Rate	[kg/h]	2094	2621	3703	5023	6160	7030	8224	9332	10560
SOURCE Water Pressure Drops	[kPa]	13	20	23	40	37	36	45	44	55
SOURCE Water effective head	[kPa]	46	32	44	40	28	14	42	28	70

5 Technical data

		GSE006	GSE009	GSE012	GSE017	GSE022	GSE025	GSE030	GSE033	GSE040
Heating										
@ 30/35°C utility										
0/-3°C source 20% glycol										
Thermal Output	[kW]	7.00	9.07	12.8	17.2	21.5	24.2	28.7	32.2	36.8
Thermal Output UNI EN 14511	[kW]	6.95	9.02	12.8	17.2	21.5	24.1	28.6	32.1	36.7
Compressor Absorbed Power	[kW]	1.62	2.01	2.85	3.82	4.74	5.35	6.24	6.98	7.94
Absorbed Power UNI EN 14511 with pumps on board	[kW]	1.50	1.90	2.73	3.70	4.64	5.24	6.12	6.86	7.90
Compressor Absorbed Current	[A]	7.82	9.70	13.75	6.12	7.61	8.59	10.01	11.2	12.73
COP	[-]	4.33	4.52	4.50	4.51	4.54	4.52	4.60	4.61	4.63
COP UNI EN 14511	[-]	4.62	4.75	4.68	4.63	4.63	4.61	4.67	4.67	4.65
UTILITY Water Flow Rate	[kg/h]	1213	1571	2219	2982	3731	4193	4971	5571	6368
UTILITY Water Pressure Drops	[kPa]	10	15	14	15	21	16	21	18	23
UTILITY Water effective head	[kPa]	57	50	60	56	72	68	91	91	81
SOURCE Water Flow Rate	[kg/h]	1678	2199	3102	4172	5228	5869	6988	7836	8970
SOURCE Water Pressure Drops	[kPa]	9	15	17	29	28	26	34	33	41
SOURCE Water effective head	[kPa]	57	45	55	64	51	39	69	61	88
DHW										
@48/55°C utility										
20/15°C source 20% glycol										
Thermal Output	[kW]	10.1	12.8	18.1	24.7	30.9	34.9	40.9	46.0	52.0
Thermal Output UNI EN 14511	[kW]	10.0	12.8	18.0	24.6	30.8	34.8	40.9	45.9	51.9
Compressor Absorbed Power	[kW]	2.55	3.15	4.53	6.04	7.40	8.47	9.93	11.0	12.6
Absorbed Power UNI EN 14511 with pumps on board	[kW]	2.43	3.03	4.41	5.91	7.27	8.32	9.77	10.9	12.5
Compressor Absorbed Current	[A]	12.30	15.20	21.88	9.69	11.87	13.59	15.92	17.69	20.21
COP	[-]	3.96	4.08	3.99	4.08	4.17	4.12	4.12	4.17	4.13
COP UNI EN 14511	[-]	4.13	4.22	4.08	4.16	4.24	4.18	4.18	4.23	4.14
UTILITY Water Flow Rate	[kg/h]	1257	1600	2249	3071	3842	4345	5097	5727	6478
UTILITY Water Pressure Drops	[kPa]	10	16	14	16	23	17	22	19	23
UTILITY Water effective head	[kPa]	56	48	59	55	68	64	89	88	79
SOURCE Water Flow Rate	[kg/h]	1408	1809	2524	3472	4371	4925	5780	6514	7349
SOURCE Water Pressure Drops	[kPa]	7	11	12	21	20	19	24	23	29
SOURCE Water effective head	[kPa]	61	54	63	80	68	58	88	82	102

5 Technical data

		GSE006	GSE009	GSE012	GSE017	GSE022	GSE025	GSE030	GSE033	GSE040
DHW										
@ 48/55°C utility										
0/-3°C source 20% glycol										
Thermal Output	[kW]	6.40	8.36	11.8	16.0	19.8	22.2	26.2	29.1	33.7
Thermal Output UNI EN 14511	[kW]	6.36	8.32	11.7	16.0	19.7	22.2	26.1	29.0	33.6
Compressor Absorbed Power	[kW]	2.67	3.26	4.60	5.96	7.15	8.45	9.95	10.8	12.1
Absorbed Power UNI EN 14511 with pumps on board	[kW]	2.58	3.15	4.50	5.84	7.02	8.29	9.80	10.6	12
Compressor Absorbed Current	[A]	12.92	15.73	22.23	9.55	11.46	13.54	15.95	17.28	19.34
COP	[-]	2.39	2.57	2.56	2.69	2.76	2.63	2.63	2.70	2.79
COP UNI EN 14511	[-]	2.47	2.64	2.61	2.74	2.81	2.68	2.67	2.74	2.80
UTILITY Water Flow Rate	[kg/h]	797	1041	1468	1996	2462	2771	3261	3623	4195
UTILITY Water Pressure Drops	[kPa]	<5	7	7	7	10	7	10	8	11
UTILITY Water effective head	[kPa]	63	60	69	67	98	94	108	108	105
SOURCE Water Flow Rate	[kg/h]	1185	1617	2275	3182	3982	4366	5135	5787	6821
SOURCE Water Pressure Drops	[kPa]	<5	9	10	18	17	15	19	19	25
SOURCE Water effective head	[kPa]	65	59	67	88	78	69	97	93	107
Maximum electric absorption										
Electrical power supply		Monofase – 230/1/50				Trifase – 400/3+N/50				
FLA tot	[A]	15	19	28	12	15	17	20	22	24
LRA	[A]	67	98	116	75	101	111	118	118	140
Noise emissions										
Lw sound power level	[dBA]	64	66	66	73	70	72	72	73	74
Compressor										
Compressor type		Scroll								
Electric motor technology		on/off								
N° compressors/cooling circuits		1/1								
Dimensions, weights and connections										
Dimensions of indoor module (H x L x P)	[mm]	1247x803x606						1462x804x607		
Weight indoor module	[kg]	290	295	300	305	310	315	320	325	330

All GSE sizes receive tax benefits as they meet the requirements of the law, II- of the DM (Ministerial Decree) 28 December 2012, following the DM 06 August 2009.

6 Mechanical assembly drawings

6 Mechanical assembly drawings

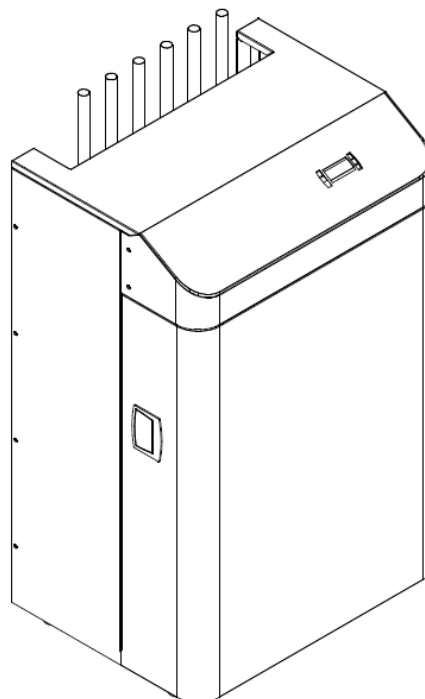
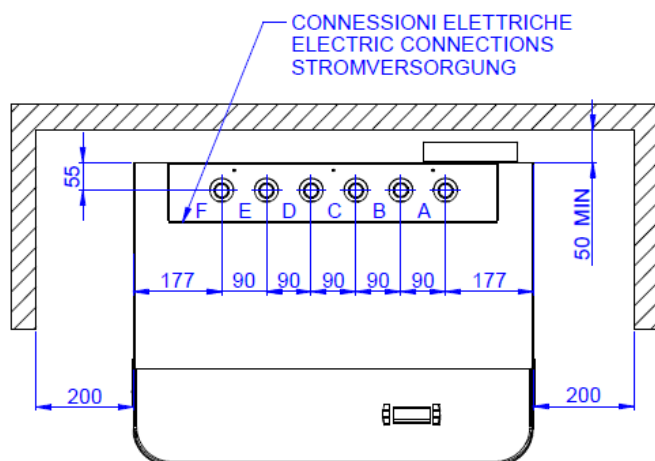
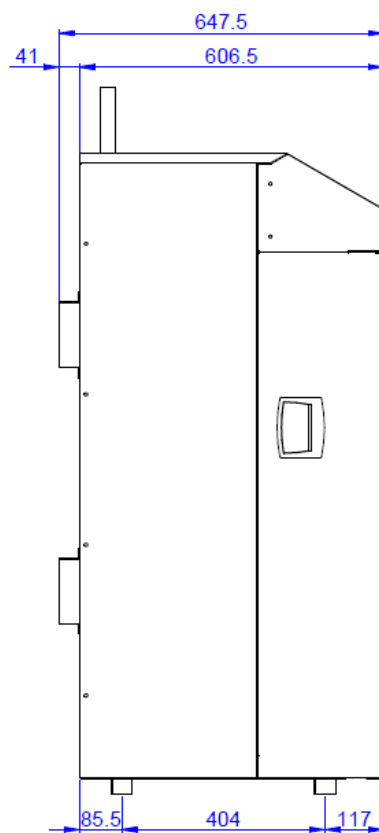
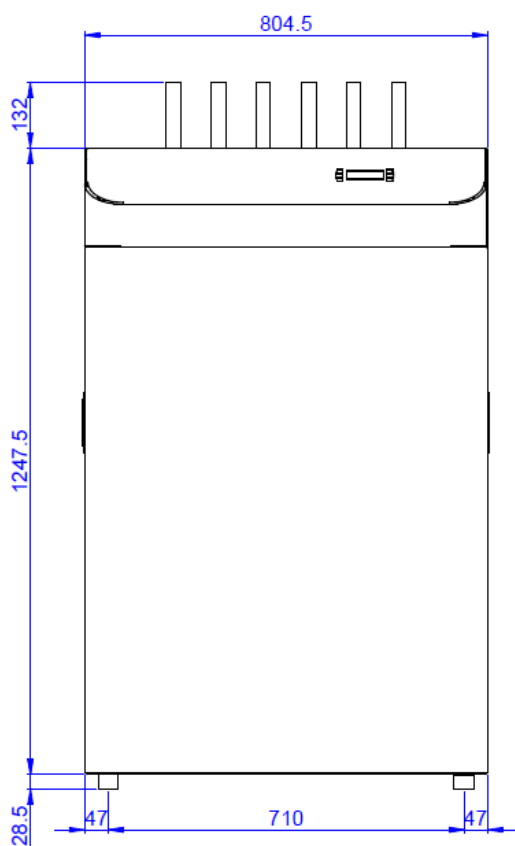

		012	022	033	044
CIRCUITO DI DISSIPAZIONE SOURCE CIRCUIT	A=	Uscita acqua Out water	Ø28 M	Ø35 M	
	B=	Ingresso acqua In water			
CIRCUITO UTILIZZATORE USER CIRCUIT	C=	Uscita acqua Out water	Ø28 M	Ø35 M	
	D=	Ingresso acqua In water			
ACQUA CALDA SANITARIA (optional) SANITARY HOT WATER (optional)	E=	Uscita acqua Out water	Ø28 M	Ø35 M	
	F=	Ingresso acqua In water			



ENEREN S.r.l.

Viale Spagna 31/33, 35020 Tribano (PD)

tel. +39 049 9271513; fax +39 049 9588522

www.eneren.it; info@eneren.it